

### 严苛选材 H13合金钢材

舍弃式设计 效率提升8倍

大幅度提高强度、硬度、耐磨性  
疲劳强度及韧性，切削强度高



优质H13合金钢

刀片与刀杆精密贴合  
严丝合缝提升产品精度

舍弃式设计 效率提升8倍

刀片与刀杆贴合度高  
加工产品精度高提升加工精度



### 双螺旋内冷孔和最优化的排屑槽设计保障顺畅排屑

高刚性、采用高精度钻杆本体使钻孔尺寸更加精准，正负10丝以内，钻杆表面采用特殊工艺处理，提高耐磨降低摩擦钻杆。规格长度2D-6D，直径12.0-100mm 直钻全规格覆盖，保证经济性，内外不同款刀片使用方便，另外常备螺纹底孔小数点U钻，管板行业和模架行业等特殊行业常用规格U钻、刀片和刀杆产品阵容不断扩充中。

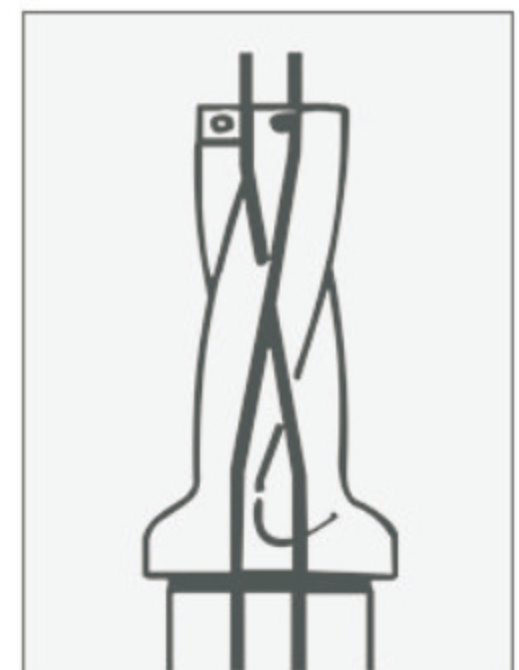

**K2D** K系列 2倍径

舍弃式钻杆/U钻/快速钻

Indexable drill holders

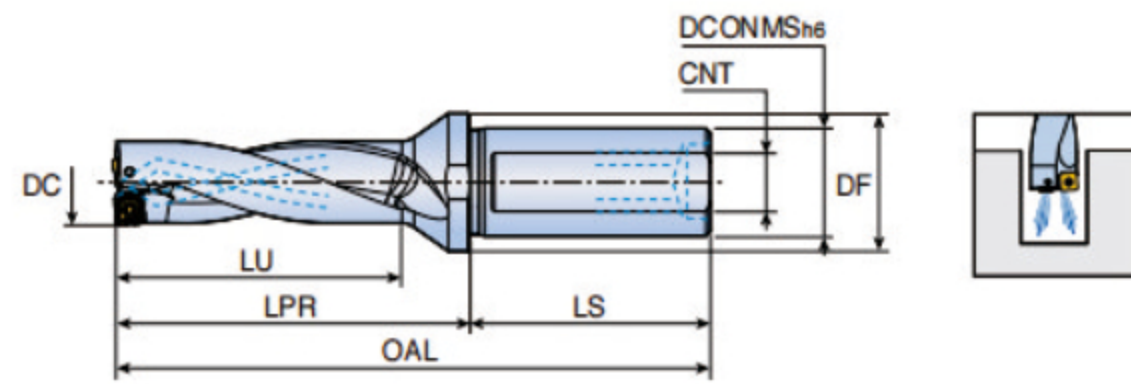

Drilling depth: 2xdiameter

钻孔深度: 2x直径

双螺旋内冷孔设计保障顺畅排屑

Helix type cooling hole accelerates smooth chip removal

型号 Designation	尺寸 Dimension(mm)					螺钉 Screw	扳手 Wrench	刀片 Insert
	DC	LU	LPR	LS	OAL			
K2D-120-20-04	12.0	27	39	47	86	M2.0x5	T6	SPMT040204-PD XOMT040204-PD
K2D-125-20-04	12.5	28	40	47	87			
K2D-130-20-04	13.0	29	41	47	88			
K2D-135-20-04	13.5	30	42	47	89			
K2D-140-25-05	14.0	31	46	53	99	M2.0x5	T6	SPMT050204-PD XOMT050204-PD
K2D-145-25-05	14.5	32	47	53	100			
K2D-150-25-05	15.0	33	48	53	101			
K2D-155-25-05	15.5	34	49	53	102			
K2D-160-25-05	16.0	35	50	53	103	M2.2x6	T7	SPMT060205-PD XOMT060204-PD
K2D-165-25-06	16.5	36	51	53	104			
K2D-170-25-06	17.0	37	52	53	105			
K2D-175-25-06	17.5	38	53	53	106			
K2D-180-25-06	18.0	39	54	53	107	M2.5x6	T7	SPMT07T208-PD XOMT07T205-PD
K2D-185-25-06	18.5	40	55	53	108			
K2D-190-25-06	19.0	41	56	53	109			
K2D-195-25-06	19.5	42	57	53	110			
K2D-200-25-07	20.0	43	58	53	111	M3.0x7	T9	SPMT090308-PD XOMT090305-PD
K2D-205-25-07	20.5	44	59	53	112			
K2D-210-25-07	21.0	45	60	53	113			
K2D-215-25-07	21.5	46	61	53	114			
K2D-220-25-07	22.0	47	62	53	115	M3.5x8	T15	SPMT11T308-PD XOMT11T306-PD
K2D-225-25-07	22.5	48	63	53	116			
K2D-230-25-07	23.0	49	64	53	117			
K2D-235-25-07	23.5	50	65	53	118			
K2D-240-25-09	24.0	51	66	53	119	M4.0x8	T15	SPMT130410-PD XOMT130406-PD
K2D-245-25-09	24.5	52	67	53	120			
K2D-250-25-09	25.0	53	68	53	121			
K2D-255-25-09	25.5	54	69	53	122			
K2D-260-32-09	26.0	55	72	57	129	M4.5x10	T20	SPMT15M510-PD XOMT15M508-PD
K2D-265-32-09	26.5	56	73	57	130			
K2D-270-32-09	27.0	57	74	57	131			
K2D-275-32-09	27.5	58	75	57	132			
K2D-280-32-09	28.0	59	76	57	133	M5x12	T20	SPMT180510-PD XOMT180508-PD
K2D-285-32-09	28.5	60	77	57	134			
K2D-290-32-09	29.0	61	78	57	135			
K2D-295-32-09	29.5	62	79	57	136			
K2D-300-32-11	30.0	63	80	57	137	M5x12	T20	SPMT180510-PD XOMT180508-PD
K2D-305-32-11	30.5	64	81	57	138			
K2D-310-32-11	31.0	65	82	57	139			
K2D-315-32-11	31.5	66	83	57	140			
K2D-320-32-11	32.0	67	84	57	141	M5x12	T20	SPMT180510-PD XOMT180508-PD
K2D-325-32-11	32.5	68	85	57	142			
K2D-330-32-11	33.0	69	86	57	143			
K2D-335-32-11	33.5	70	87	57	144			
K2D-340-32-11	34.0	71	88	57	145	M5x12	T20	SPMT180510-PD XOMT180508-PD
K2D-345-32-11	34.5	72	89	57	146			
K2D-350-32-11	35.0	73	90	57	147			
K2D-355-32-11	35.5	74	91	57	148			
K2D-360-32-13	36.0	75	92	57	149	M5x12	T20	SPMT180510-PD XOMT180508-PD
K2D-365-32-13	36.5	76	93	57	150			
K2D-370-32-13	37.0	77	94	57	151			
K2D-375-32-13	37.5	78	95	57	152			
K2D-380-32-13	38.0	79	96	57	153	M5x12	T20	SPMT180510-PD XOMT180508-PD
K2D-385-32-13	38.5	80	97	57	154			
K2D-390-32-13	39.0	81	98	57	155			
K2D-395-32-13	39.5	82	99	57	156			
K2D-400-32-13	40.0	83	100	57	157	M5x12	T20	SPMT180510-PD XOMT180508-PD
K2D-410-32-13	41.0	85	102	57	159			
K2D-420-40-13	42.0	87	105	62	167			
K2D-430-40-15	43.0	89	107	62	169			
K2D-440-40-15	44.0	91	109	62	171			
K2D-450-40-15	45.0	93	110	62	173			
K2D-460-40-15	46.0	95	113	62	175			
K2D-470-40-15	47.0	97	115	62	177	M5x12	T20	SPMT180510-PD XOMT180508-PD
K2D-480-40-15	48.0	99	117	62	179			
K2D-490-40-15	49.0	101	119	62	181			
K2D-500-40-15	50.0	103	121	62	183			
K2D-510-40-18	51.0	108	148	70	218	M5x12	T20	SPMT180510-PD XOMT180508-PD
K2D-520-40-18	52.0	110	150	70	220			
K2D-530-40-18	53.0	112	152	70	222			
K2D-540-40-18	54.0	114	154	70	224			
K2D-550-40-18	55.0	116	156	70	226	M5x12	T20	SPMT180510-PD XOMT180508-PD
K2D-560-40-18	56.0	118	160	70	230			
K2D-570-40-18	57.0	121	163	70	233			
K2D-580-40-18	58.0	124	166	70	236			
K2D-590-40-18	59.0	127	169	70	239	M5x12	T20	SPMT180510-PD XOMT180508-PD
K2D-600-40-18	60.0	130	172	70	242			

**K3D** K系列 3倍径

舍弃式钻杆/U钻/快速钻

Indexable drill holders

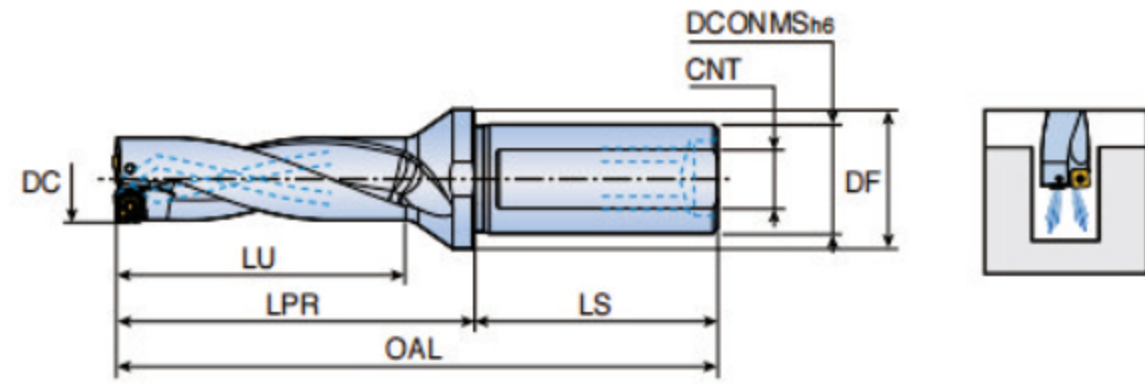

Drilling depth: 3xdiameter

钻孔深度: 3x直径

双螺旋内冷孔设计保障顺畅排屑

Helix type cooling hole accelerates smooth chip removal

型号 Designation	尺寸 Dimension(mm)					螺钉 Screw	扳手 Wrench	刀片 Insert
	DC	LU	LPR	LS	OAL			
K3D-120-20-04	12.0	39	51	47	98	M2.0x5	T6	SPMT040204-PD XOMT040204-PD
K3D-125-20-04	12.5	40.5	52.5	47	99.5			
K3D-130-20-04	13.0	42	54	47	101			
K3D-135-20-04	13.5	43.5	55.5	47	102.5			
K3D-140-25-05	14.0	45	60	53	113	M2.0x5	T6	SPMT050204-PD XOMT050204-PD
K3D-145-25-05	14.5	46.5	61.5	53	114.5			
K3D-150-25-05	15.0	48	63	53	116			
K3D-155-25-05	15.5	49.5	64.5	53	117.5			
K3D-160-25-05	16.0	51	66	53	119	M2.2x6	T7	SPMT060205-PD XOMT060204-PD
K3D-165-25-06	16.5	52.5	67.5	53	120.5			
K3D-170-25-06	17.0	54	69	53	122			
K3D-175-25-06	17.5	55.5	70.5	53	123.5			
K3D-180-25-06	18.0	57	72	53	125	M2.5x6	T7	SPMT07T208-PD XOMT07T205-PD
K3D-185-25-06	18.5	58.5	73.5	53	126.5			
K3D-190-25-06	19.0	60	75	53	128			
K3D-195-25-06	19.5	61.5	76.5	53	129.5			
K3D-200-25-07	20.0	63	78	53	131	M3.0x7	T9	SPMT090308-PD XOMT090305-PD
K3D-205-25-07	20.5	64.5	79.5	53	132.5			
K3D-210-25-07	21.0	66	81	53	134			
K3D-215-25-07	21.5	67.5	82.5	53	135.5			
K3D-220-25-07	22.0	69	84	53	137	M3.5x8	T15	SPMT11T308-PD XOMT11T306-PD
K3D-225-25-07	22.5	70.5	85.5	53	138.5			
K3D-230-25-07	23.0	72	87	53	140			
K3D-235-25-07	23.5	73.5	88.5	53	141.5			
K3D-240-25-09	24.0	75	90	53	143	M4.0x8	T15	SPMT130410-PD XOMT130406-PD
K3D-245-25-09	24.5	76.5	91.5	53	144.5			
K3D-250-25-09	25.0	78	93	53	146			
K3D-255-25-09	25.5	79.5	94.5	53	147.5			
K3D-260-32-09	26.0	81	98	57	155	M4.5x10	T20	SPMT15M510-PD XOMT15M508-PD
K3D-265-32-09	26.5	82.5	99.5	57	156.5			
K3D-270-32-09	27.0	84	101	57	158			
K3D-275-32-09	27.5	85.5	102.5	57	159.5			
K3D-280-32-09	28.0	87	104	57	161	M5x12	T20	SPMT180510-PD XOMT180508-PD
K3D-285-32-09	28.5	88.5	105.5	57	162.5			
K3D-290-32-09	29.0	90	107	57	164			
K3D-295-32-09	29.5	91.5	108.5	57	165.5			
K3D-300-32-11	30.0	93	110	57	167	M5x12	T20	SPMT180510-PD XOMT180508-PD
K3D-305-32-11	30.5	94.5	111.5	57	168.5			
K3D-310-32-11	31.0	96	113	57	170			
K3D-315-32-11	31.5	97.5	114.5	57	171.5			
K3D-320-32-11	32.0	99	116	57	173	M5x12	T20	SPMT180510-PD XOMT180508-PD
K3D-325-32-11	32.5	100.5	117.5	57	174.5			
K3D-330-32-11	33.0	102	119	57	176			
K3D-335-32-11	33.5	103.5	120.5	57	177.5			
K3D-340-32-11	34.0	105	122	57	179	M5x12	T20	SPMT180510-PD XOMT180508-PD
K3D-345-32-11	34.5	106.5	123.5	57	180.5			
K3D-350-32-11	35.0	108	125	57	182			
K3D-355-32-11	35.5	109.5	126.5	57	183.5			
K3D-360-32-13	36.0	111	128	57	185	M5x12	T20	SPMT180510-PD XOMT180508-PD
K3D-365-32-13	36.5	112.5	129.5	57	186.5			
K3D-370-32-13	37.0	114	131	57	188			
K3D-375-32-13	37.5	115.5	132.5	57	189.5			
K3D-380-32-13	38.0	117	134	57	191	M5x12	T20	SPMT180510-PD XOMT180508-PD
K3D-385-32-13	38.5	118.5	135.5	57	192.5			
K3D-390-32-13	39.0	120	137	57	194			
K3D-395-32-13	39.5	121.5	138.5	57	195.5			
K3D-400-32-13	40.0	123	140	57	197	M5x12	T20	SPMT180510-PD XOMT180508-PD
K3D-410-32-13	41.0	126	143	57	200			
K3D-420-40-13	42.0	129	147	62	209			
K3D-430-40-15	43.0	132	150	62	212			
K3D-440-40-15	44.0	135	153	62	215	M5x12	T20	SPMT180510-PD XOMT180508-PD
K3D-450-40-15	45.0	138	156	62	218			
K3D-460-40-15	46.0	141	159	62	221			
K3D-470-40-15	47.0	144	162	62	224			
K3D-480-40-15	48.0	147	165	62	227	M5x12	T20	SPMT180510-PD XOMT180508-PD
K3D-490-40-15	49.0	150	168	62	230			
K3D-500-40-15	50.0	153	171	62	233			
K3D-510-40-18	51.0	159	199	70	269			
K3D-520-40-18	52.0	162	202	70	272			
K3D-530-40-18	53.0	165	205	70	275			
K3D-540-40-18	54.0	168	208	70	278			
K3D-550-40-18	55.0	171	211	70	281	M5x12	T20	SPMT180510-PD XOMT180508-PD
K3D-560-40-18	56.0	174	216	70	286			
K3D-570-40-18	57.0	178	220	70	290			
K3D-580-40-18	58.0	182	224	70	294			
K3D-590-40-18	59.0	186	228	70	298	M5x12	T20	SPMT180510-PD XOMT180508-PD
K3D-600-40-18	60.0	190	232	70	302			

**K4D** K系列 4倍径

舍弃式钻杆/U钻/快速钻

Indexable drill holders

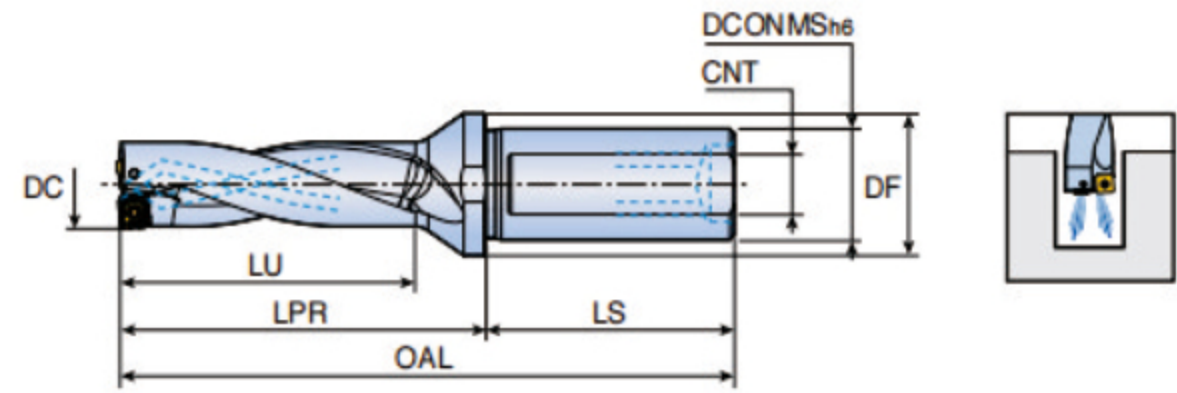

Drilling depth: 4xdiameter

钻孔深度: 4x直径

双螺旋内冷孔设计保障顺畅排屑

Helix type cooling hole accelerates smooth chip removal

型号 Designation	尺寸Dimension(mm)					螺钉 Screw	扳手 Wrench	刀片 Insert
	DC	LU	LPR	LS	OAL			
K4D-120-20-04	12.0	51	63	47	110	M2.0x5	T6	SPMT040204-PD XOMT040204-PD
K4D-125-20-04	12.5	53	65	47	112			
K4D-130-20-04	13.0	55	67	47	114			
K4D-135-20-04	13.5	57	69	47	116			
K4D-140-25-05	14.0	59	74	53	127	M2.0x5	T6	SPMT050204-PD XOMT050204-PD
K4D-145-25-05	14.5	61	76	53	129			
K4D-150-25-05	15.0	63	78	53	131			
K4D-155-25-05	15.5	65	80	53	133			
K4D-160-25-05	16.0	67	82	53	135	M2.2x6	T7	SPMT060205-PD XOMT060204-PD
K4D-165-25-06	16.5	69	84	53	137			
K4D-170-25-06	17.0	71	86	53	139			
K4D-175-25-06	17.5	73	88	53	141			
K4D-180-25-06	18.0	75	90	53	143	M2.5x6	T7	SPMT07T208-PD XOMT07T205-PD
K4D-185-25-06	18.5	77	92	53	145			
K4D-190-25-06	19.0	79	94	53	147			
K4D-195-25-06	19.5	81	96	53	149			
K4D-200-25-07	20.0	83	98	53	151	M3.0x7	T9	SPMT090308-PD XOMT090305-PD
K4D-205-25-07	20.5	85	100	53	153			
K4D-210-25-07	21.0	87	102	53	155			
K4D-215-25-07	21.5	89	104	53	157			
K4D-220-25-07	22.0	91	106	53	159	M3.5x8	T15	SPMT11T308-PD XOMT11T306-PD
K4D-225-25-07	22.5	93	108	53	161			
K4D-230-25-07	23.0	95	110	53	163			
K4D-235-25-07	23.5	97	112	53	165			
K4D-240-25-09	24.0	99	114	53	167	M4.0x8	T15	SPMT130410-PD XOMT130406-PD
K4D-245-25-09	24.5	101	116	53	169			
K4D-250-25-09	25.0	103	118	53	171			
K4D-255-25-09	25.5	105	120	53	173			
K4D-260-32-09	26.0	107	124	57	181	M4.5x10	T20	SPMT15M510-PD XOMT15M508-PD
K4D-265-32-09	26.5	109	126	57	183			
K4D-270-32-09	27.0	111	128	57	185			
K4D-275-32-09	27.5	113	130	57	187			
K4D-280-32-09	28.0	115	132	57	189	M5x12	T20	SPMT180510-PD XOMT180508-PD
K4D-285-32-09	28.5	117	134	57	191			
K4D-290-32-09	29.0	119	136	57	193			
K4D-295-32-09	29.5	121	138	57	195			
K4D-300-32-11	30.0	123	140	57	197	M5x12	T20	SPMT180510-PD XOMT180508-PD
K4D-305-32-11	30.5	125	142	57	199			
K4D-310-32-11	31.0	127	144	57	201			
K4D-315-32-11	31.5	129	146	57	203			
K4D-320-32-11	32.0	131	148	57	205	M5x12	T20	SPMT180510-PD XOMT180508-PD
K4D-325-32-11	32.5	133	150	57	207			
K4D-330-32-11	33.0	135	152	57	209			
K4D-335-32-11	33.5	137	154	57	211			
K4D-340-32-11	34.0	139	156	57	213	M5x12	T20	SPMT180510-PD XOMT180508-PD
K4D-345-32-11	34.5	141	158	57	215			
K4D-350-32-11	35.0	143	160	57	217			
K4D-355-32-11	35.5	145	162	57	219			
K4D-360-32-13	36.0	147	164	57	221	M5x12	T20	SPMT180510-PD XOMT180508-PD
K4D-365-32-13	36.5	149	166	57	223			
K4D-370-32-13	37.0	151	168	57	225			
K4D-375-32-13	37.5	153	170	57	227			
K4D-380-32-13	38.0	155	172	57	229	M5x12	T20	SPMT180510-PD XOMT180508-PD
K4D-385-32-13	38.5	157	174	57	231			
K4D-390-32-13	39.0	159	176	57	233			
K4D-395-32-13	39.5	161	178	57	235			
K4D-400-32-13	40.0	163	180	57	237	M5x12	T20	SPMT180510-PD XOMT180508-PD
K4D-410-32-13	41.0	167	184	57	241			
K4D-420-40-13	42.0	171	189	62	251			
K4D-430-40-15	43.0	175	193	62	255			
K4D-440-40-15	44.0	179	197	62	259	M5x12	T20	SPMT180510-PD XOMT180508-PD
K4D-450-40-15	45.0	183	201	62	263			
K4D-460-40-15	46.0	187	205	62	267			
K4D-470-40-15	47.0	191	209	62	271			
K4D-480-40-15	48.0	195	213	62	275	M5x12	T20	SPMT180510-PD XOMT180508-PD
K4D-490-40-15	49.0	199	217	62	279			
K4D-500-40-15	50.0	203	221	62	283			
K4D-510-40-18	51.0	210	250	70	320			
K4D-520-40-18	52.0	214	254	70	324			
K4D-530-40-18	53.0	218	258	70	328			
K4D-540-40-18	54.0	222	262	70	332			
K4D-550-40-18	55.0	226	266	70	336	M5x12	T20	SPMT180510-PD XOMT180508-PD
K4D-560-40-18	56.0	230	272	70	342			
K4D-570-40-18	57.0	235	277	70	347			
K4D-580-40-18	58.0	240	282	70	352			
K4D-590-40-18	59.0	245	287	70	357	M5x12	T20	SPMT180510-PD XOMT180508-PD
K4D-600-40-18	60.0	250	292	70	362			

**K5D** K系列 5倍径

舍弃式钻杆/U钻/快速钻

Indexable drill holders

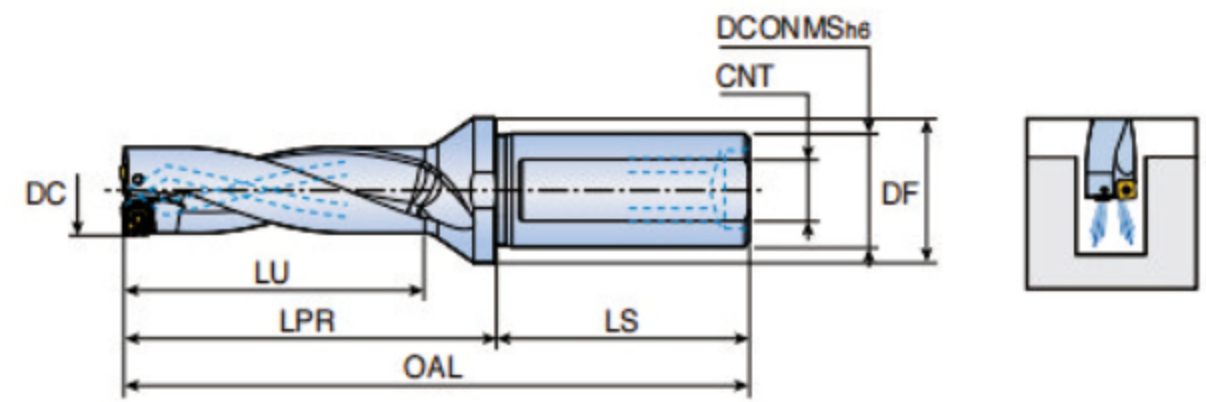

Drilling depth: 5xdiameter

钻孔深度: 5x直径

双螺旋内冷孔设计保障顺畅排屑

Helix type cooling hole accelerates smooth chip removal

型号 Designation	尺寸 Dimension(mm)					螺钉 Screw	扳手 Wrench	刀片 Insert
	DC	LU	LPR	LS	OAL			
K5D-120-20-04	12.0	63	75	47	122	M2.0x5	T6	SPMT040204-PD XOMT040204-PD
K5D-125-20-04	12.5	65.5	77.5	47	124.5			
K5D-130-20-04	13.0	68	80	47	127			
K5D-135-20-04	13.5	70.5	82.5	47	129.5			
K5D-140-25-05	14.0	73	88	53	141	M2.0x5	T6	SPMT050204-PD XOMT050204-PD
K5D-145-25-05	14.5	75.5	90.5	53	143.5			
K5D-150-25-05	15.0	78	93	53	146			
K5D-155-25-05	15.5	80.5	95.5	53	148.5			
K5D-160-25-05	16.0	83	98	53	151	M2.2x6	T7	SPMT060205-PD XOMT060204-PD
K5D-165-25-06	16.5	85.5	100.5	53	153.5			
K5D-170-25-06	17.0	88	103	53	156			
K5D-175-25-06	17.5	90.5	105.5	53	158.5			
K5D-180-25-06	18.0	93	108	53	161	M2.5x6	T7	SPMT07T208-PD XOMT07T205-PD
K5D-185-25-06	18.5	95.5	110.5	53	163.5			
K5D-190-25-06	19.0	98	113	53	166			
K5D-195-25-06	19.5	100.5	115.5	53	168.5			
K5D-200-25-07	20.0	103	118	53	171	M3.0x7	T9	SPMT090308-PD XOMT090305-PD
K5D-205-25-07	20.5	105.5	120.5	53	173.5			
K5D-210-25-07	21.0	108	123	53	176			
K5D-215-25-07	21.5	110.5	125.5	53	178.5			
K5D-220-25-07	22.0	113	128	53	181	M3.5x8	T15	SPMT11T308-PD XOMT11T306-PD
K5D-225-25-07	22.5	115.5	130.5	53	183.5			
K5D-230-25-07	23.0	118	133	53	186			
K5D-235-25-07	23.5	120.5	135.5	53	188.5			
K5D-240-25-09	24.0	123	138	53	191	M4.0x8	T15	SPMT130410-PD XOMT130406-PD
K5D-245-25-09	24.5	125.5	140.5	53	193.5			
K5D-250-25-09	25.0	128	143.5	53	196			
K5D-255-25-09	25.5	130.5	145.5	53	198.5			
K5D-260-32-09	26.0	133	150	57	207	M4.5x10	T20	SPMT15M510-PD XOMT15M508-PD
K5D-265-32-09	26.5	135.5	152.5	57	209.5			
K5D-270-32-09	27.0	138	155	57	212			
K5D-275-32-09	27.5	140.5	157.5	57	214.5			
K5D-280-32-09	28.0	143	160	57	217	M5x12	T20	SPMT180510-PD XOMT180508-PD
K5D-285-32-09	28.5	145.5	162.5	57	219.5			
K5D-290-32-09	29.0	148	165	57	222			
K5D-295-32-09	29.5	150.5	167.5	57	224.5			
K5D-300-32-11	30.0	153	170	57	227	M5x12	T20	SPMT180510-PD XOMT180508-PD
K5D-305-32-11	30.5	155.5	172.5	57	229.5			
K5D-310-32-11	31.0	158	175	57	232			
K5D-315-32-11	31.5	160.5	177.5	57	234.5			
K5D-320-32-11	32.0	163	180	57	237	M5x12	T20	SPMT180510-PD XOMT180508-PD
K5D-325-32-11	32.5	165.5	182.5	57	239.5			
K5D-330-32-11	33.0	168	185	57	242			
K5D-335-32-11	33.5	170.5	187.5	57	244.5			
K5D-340-32-11	34.0	173	190	57	247	M5x12	T20	SPMT180510-PD XOMT180508-PD
K5D-345-32-11	34.5	175.5	192.5	57	249.5			
K5D-350-32-11	35.0	178	195	57	252			
K5D-355-32-11	35.5	180.5	197.5	57	254.5			
K5D-360-32-13	36.0	183	200	57	257	M5x12	T20	SPMT180510-PD XOMT180508-PD
K5D-365-32-13	36.5	185.5	202.5	57	259.5			
K5D-370-32-13	37.0	188	205	57	262			
K5D-375-32-13	37.5	190.5	207.5	57	264.5			
K5D-380-32-13	38.0	193	210	57	267	M5x12	T20	SPMT180510-PD XOMT180508-PD
K5D-385-32-13	38.5	195.5	212.5	57	269.5			
K5D-390-32-13	39.0	198	215	57	272			
K5D-395-32-13	39.5	200.5	217.5	57	274.5			
K5D-400-32-13	40.0	203	220	57	277	M5x12	T20	SPMT180510-PD XOMT180508-PD
K5D-410-32-13	41.0	208	225	57	282			
K5D-420-40-13	42.0	213	231	62	293			
K5D-430-40-15	43.0	218	236	62	298			
K5D-440-40-15	44.0	223	241	62	303			
K5D-450-40-15	45.0	228	246	62	308			
K5D-460-40-15	46.0	233	251	62	313			
K5D-470-40-15	47.0	238	256	62	318	M5x12	T20	SPMT180510-PD XOMT180508-PD
K5D-480-40-15	48.0	243	261	62	323			
K5D-490-40-15	49.0	248	266	62	328			
K5D-500-40-15	50.0	253	271	62	333			
K5D-510-40-18	51.0	261	199	70	371	M5x12	T20	SPMT180510-PD XOMT180508-PD
K5D-520-40-18	52.0	266	202	70	376			
K5D-530-40-18	53.0	271	205	70	381			
K5D-540-40-18	54.0	276	208	70	386			
K5D-550-40-18	55.0	281	211	70	391	M5x12	T20	SPMT180510-PD XOMT180508-PD
K5D-560-40-18	56.0	286	216	70	398			
K5D-570-40-18	57.0	292	220	70	404			
K5D-580-40-18	58.0	298	224	70	410			
K5D-590-40-18	59.0	304	228	70	416	M5x12	T20	SPMT180510-PD XOMT180508-PD
K5D-600-40-18	60.0	310	232	70	422			

钻头直径 ( mm )	外刃刀片	内刃刀片	扳手	螺丝
Φ12.0-Φ13.5	SPMT040204	XOMT040204	FTNA0204	TW06P
Φ14.0-Φ16.0	SPMT050204	XOMT050204	FTNA0204	TW06P
Φ16.1-Φ19.5	SPMT060205	XOMT060204	FTKA02206S	TW07P
Φ19.6-Φ23.5	SPMT07T208	XOMT07T205	FTKA02565	TW07S
Φ23.6-Φ29.5	SPMT090308	XOMT090305	FTKA0307	TW09S
Φ29.6-Φ35.5	SPMT11T308	XOMT11T306	FTKA03508	TW15S
Φ35.6-Φ42.5	SPMT130410	XOMT130406	FTKA0410	TW15S
Φ42.6-Φ50.5	SPMT15M510	XOMT15M508	FTKC04511	TW20S
Φ50.6-Φ60.5	SPMT180510	XOMT180508	FTKA0511	TW20-100
Φ61-Φ65	XOMT11T306	SPMT11T308	FTKA03508	TW15S
Φ65-Φ70	XOMT130406	SPMT130410	FTKA0410	TW15S
Φ70-Φ75	XOMT130406	SPMT130410	FTKA0410	TW15S
Φ75-Φ80	XOMT130406	SPMT130410	FTKA0410	TW15S
Φ80-Φ85	XOMT15M508	SPMT15M510	FTNC04511	TW20S
Φ85-Φ90	XOMT15M508	SPMT15M510	FTNC04511	TW20S
Φ90-Φ95	XOMT15M508	SPMT15M510	FTNC04511	TW20S

## 产品特点/ Product Features

- 01** 超过HRC50度的高硬度刀体，高刚性延长刀片的寿命  
High hardness drill body over HRC50, High rigidity prolongs the tool life



- 02** 双螺旋内冷设计扩大了槽深和冷却孔径，排屑更顺畅  
Double helix coolant design expands flute depth and hole diameter, Smoother chip flow



- 03** 特殊的表面处理起到减少阻力和提高耐磨损的性能  
Special surface treatment reduces resistance, Improve wear resistance performance.

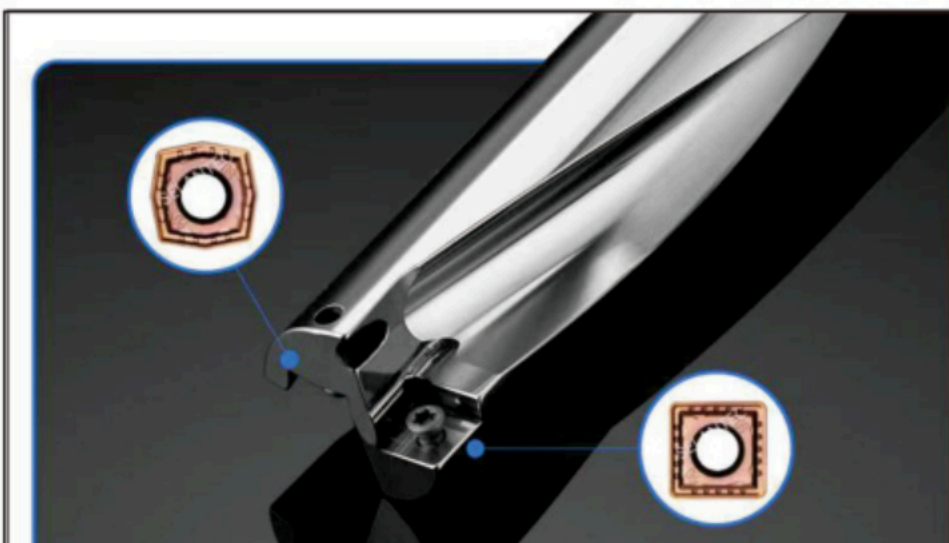

- 04** 采用四刃设计和内外相同刀片，达到更高的经济性  
Adopting a four cornered design and same internal and external inserts to achieve higher economic efficiency.

